

SmartStack Patient Care Stand

SENSING

ANALYSIS

DELIVERY

"Designed for ultimate efficiency & durability"



24" Wide Base Design Leaves
Wider Footprint for Added Applications



Adjust Pole Quickly w/ Ease

Sturdy Base for Added
Stability & Durability



SMARTSTACK OVERVIEW

The space-saving **SmartStack** patient care stand from Maxtec has a specially designed 24" base that provides extra support and durability. Its patented design will stack neatly with other bases of its kind (22" and 24" SmartStacks), creating extra storage space, a more organized facility, and easy transportation of multiple stands at once.

PART NUMBERS

SmartStack Single-Pack R100P49-001

SmartStack w/ IV Pole Basket R100P49-006

SmartStack Bulk (48 minimum) R100P49-008

**To order bulk, contact your sales rep.*

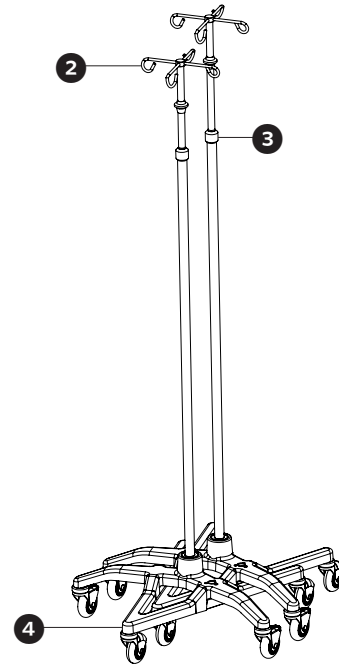
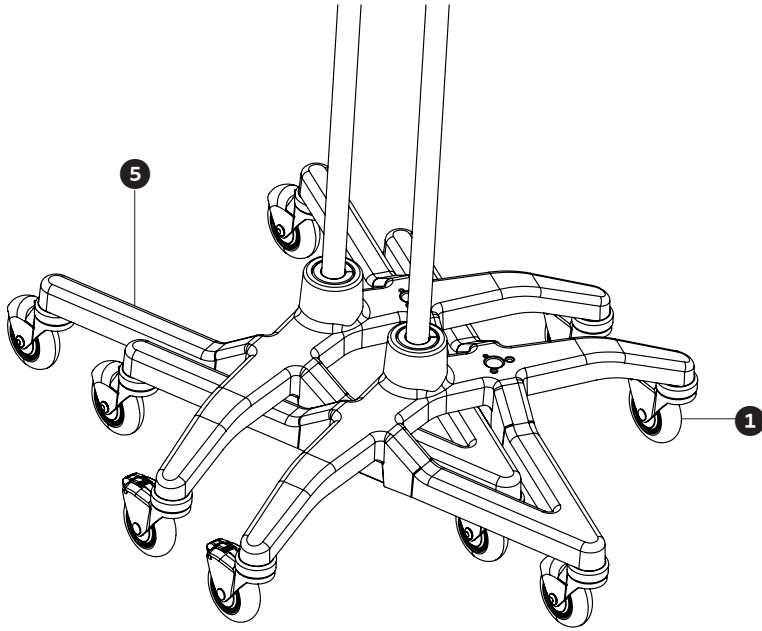

1. Large, Smooth Rolling Caster

Rolls smoothly and quietly on all floor surfaces

2. Includes 4 fixed Ram-Horn Hooks

Can hold up to 50 lbs on top portion

3. Easy Adjustment

One-handed height adjustment

4. Wide Base

24" base for added applications

5. Heavy Base

Sturdy base creates added durability and increased weight capacity.

Specifications

Collapsed Height	Pole 54", Pole w/ Base 61" (measured from floor to top of hook assembly)
Extended Height	Pole Extended 86", Pole w/ Base 93" (measured from floor to top of hook assembly)
Casters	Neoprene Tread, Chrome Steel, 3" QTY: 5, 2 Locking, 3 Non-Locking
Weight Capacity	100lbs Total, 50lbs on Top Portion, 11lb Maximum One Hook
Wheel Base Diameter	24"
Nesting Base	5" (center to center)
Weight	19lbs
Shipping Weight	Base: 113lbs, Poles 28lbs (six units)
Pole Diameter	25mm (bottom portion) 18mm (upper portion)
Base Material	Powder coated aluminum
Pole Material	Stainless Steel
Ram-Horn Hooks	4 fixed
Restrictions	Not MRI Compatible